

400C SERIES

ALUMINUM EXIT SIGN COMBO WITH LED EMERGENCY LIGHTS

The 400C Series is the very first LED die-cast aluminum exit/emergency combo unit available, combining an appealing design, the latest in die cast technology, and high performance electronics to ensure reliability.

FEATURES

- Unique design, LED die-cast combo provides a spec-grade, low profile exit sign with LED emergency lights using only 3 watts per lamp
- Each lamp head is protected by a polycarbonate shield
- Maintenance-free NiCad battery
- Ceiling, wall or end mount
- UL listed 90 minute emergency run time, 24 hour recharge time
- Constant, uniform illumination by long-life, high intensity, red or green LEDs
- Fully-illuminated 6" characters with 3/4" stroke
- Field selectable directional chevron knockouts
- 120/277V dual primary, 60Hz input
- Standard finishes: Black, white or brushed aluminum

WARRANTY

Any component that fails due to manufacturers defect is guaranteed for 5 years with a separate 5 year pro-rated warranty on the battery. The warranty does not cover physical damage, abuse or instances of uncontrollable natural forces. Manufacturer reserves the right to charge for such repairs if deemed necessary.



ORDERING INFORMATION Example: 400C-1-BA

Series	Face	Finish	Accessories ² (Field Installed)
400C = Red LEDs	1 = Single Face	BL = Black w/ Alum. Face	WG-1 = Wire Guard (Back Mount)
G400C = Green LEDs	2 = Double Face	BB = Black w/ Black Face	WG-2 = Wire Guard (End Mount)
		WW = White w/ White Face	WG-3 = Wire Guard (Ceiling Mount)
		BA = Brushed Alum. w/ Alum. Face	XG-6 = Poly Guard (Back Mount)
Notes			ER1-Kit ¹ = Pendant Mount Kit
¹ Requires VEPA option			ER2-Kit ¹ = Pendant Mount Kit
² Order as separate line item			VEPA = Pendant Adaptor

CONSTRUCTION

The Exitronix 400C is constructed of rugged die-cast aluminum body with soft corners (designed for traditional mounting as well as conduit entry and pendant mounting). Clear finish on brushed face prevents fingerprints or other surface impurities. Field selectable chevron knockouts are concealed and easily removed. All units are supplied with mounting canopy for back, ceiling or end mounting.

ILLUMINATION

Illumination is accomplished utilizing high-intensity, long-life LEDs exceeding UL 924 requirements for brightness and uniformity, while maximizing energy efficiency.

ELECTRICAL

Input

Dual-voltage input 120 or 277VAC @ 60Hz.

Nickel Cadmium Battery - NiCad

Exitronix nickel cadmium batteries are maintenance-free with a life expectancy of 15 years. Nickel cadmium batteries offer high discharge rates and continue to perform in a vast temperature range from 32°F - 104°F (0°C - 40°C).

Solid-State Transfer

The circuit features solid-state switching for emergency lamps, eliminating concerns of damaged contact or mechanical failures associated with relays. The switching circuit detects a loss of line voltage and automatically switches to emergency mode.

Brownout Circuit

Brownout circuit monitors the line voltage, as the line voltage sags and can no longer illuminate the exit sign to meet UL 924 visibility test, the emergency circuit will turn on to supply a portion or all the power to illuminate the sign for a minimum of 90mins until the line voltage is restored.

Test Button

The test button is easy to locate and provides manual verification of the transfer circuit and emergency lamps.

INSTALLATION

Installs in minutes with easy-to-read instructions and detailed diagrams. No special hardware or tools necessary. Internally housed components and battery eliminate the risk of damage during installation. Mounting canopy included.

CONFORMANCE TO CODES & STANDARDS

The 400C Series is UL listed and meets or exceeds the following: UL 924, NEC requirements and NFPA 101.

SAMPLE PHOTOMETRICS

Using multiple units mounted at a typical 7.17' delivers 16' center-to-center spacing on a 3' wide egress path.

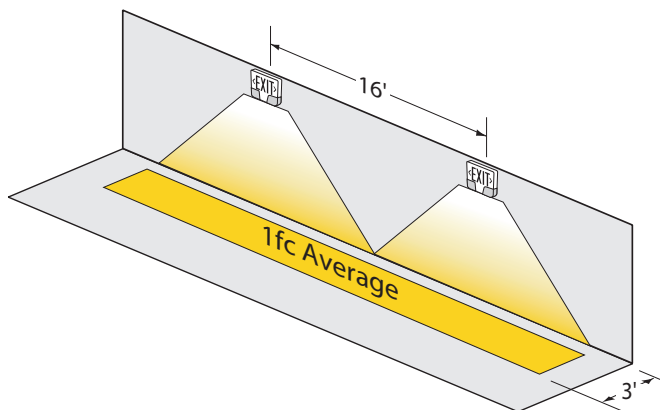

DIMENSIONS

