

EXTREME SERIES **NEMA 4X EMERGENCY LIGHT**



OVERVIEW

The EXT Series NEMA 4X Extreme Emergency Light is suitable for hazardous locations that feature flammable, ignitable, or explosive gases, vapors, or dust particles. Available in a variety of battery voltage and wattage combinations.

Two front-mounted MR16 style lamp heads produce powerful emergency illumination that lasts for a minimum 90 minutes. UL924 Listed for the US and Canada. A push-to-test button allows for easy testing of the battery backup system.

This wet location emergency light back mounts to normally inflammable surfaces. Operates using 120 or 277V AC power, special voltages available.

This NEMA 4X emergency light is easy to install and is suitable for oil refineries, power plants, and chemical processing facilities. A powerful battery backup system provides a minimum 90 minutes of emergency illumination during power outages.

Auto-Testing (AT) Diagnostics are optional on this outdoor rated emergency light. All of the wet location emergency lights are outfitted with the latest fixture monitoring technology.

FEATURES

- Rated for NEMA 4X outdoor/wet locations
- Gray polycarbonate constructed housing
- Push-to-test button with LED charging indicator
- NEMA 3, 4, 4x, and 12 Rated
- UL 924 Listed for the USA
- 3 year warranty

EXTERNAL SPECIFICATIONS

The EXT Series is constructed from fiberglass reinforced polyester and is approved for a variety of extreme wet and outdoor locations. This wet location emergency lights is approved for NEMA 3, 4, 4x, 12 areas. NSF Rated for food processing facilities.

Water and corrosion-resistant cabinet is made of fiberglassreinforced polyester. Industrial gray cabinet is fully gasketed around the cover. Battery compartment is vented with a breather vent designed to permit exhaust of battery gases without admitting external moisture or corrosives.

A clear polycarbonate shield creates a window that allows for easy monitoring of the AC indicator light and optional ammeter and voltmeter. Comes standard with NEMA 4X rated polycarbonate sealed beam PAR 36 halogen or tungsten lamp heads.

LAMP SELECTION GUIDE

- **MR16**
10W (6V) or 10W, 12W, and 20W (12V)
- **LED MR16**
5W (6V) or 3W, 5W, and 7W (12V)

BATTERY

The EXT uses Ni-Cad and Lead-Acid batteries to provide a minimum 90 minutes of power to the (2) lamp heads. Remotely located lamp heads can be configured for extended run times of up to 4.5 hours.

ELECTRICAL SPECIFICATIONS

120/277V AC dual-voltage operation is standard. Other voltages available upon request such as 220v and 240v.

SELF-DIAGNOSTIC TESTING

Optional Auto-Testing (AT) Diagnostics circuitry continuously monitors every critical function of the unit. If a problem occurs, a single fault indicator on the outside of the fixture flashes immediately.

A detailed diagnostic display is located internally. The detailed display will further indicate the nature of the fault as either a battery fault, load fault or a charger fault.

COLD WEATHER BATTERY HEATER

Internal battery heater "IH" option insures the unit will operate in temperatures as low as -4°F. This is accomplished with a thermostatic heater that begins operating when temperatures drop below 40°F.

ADDITIONAL OPTIONS

Additional options include a Wire Guard (WG), Voltmeter (VM), and Nickel-Cadmium Battery (NC). Consult the ordering matrix below for more information on available options for the BRV Series.

CODE COMPLIANCE

UL924 Listed for the U.S. and Canada, CS860, NFPA, Life Safety 101, UL Listed for Damp Locations. UL Listed for Wet Locations. NSF Standard 2.

WARRANTY

The EXT Series comes with a 3-year factory warranty. The lamps are not covered. Deliberate damage, misuse, or improper installation effectively cancel the warranty. Battery features a 20% per year pro-rata warranty.



DIMENSIONS

- A** = 16.25" (413mm)
- B** = 7.5" (191mm)
- C** = 6.0" (152mm)

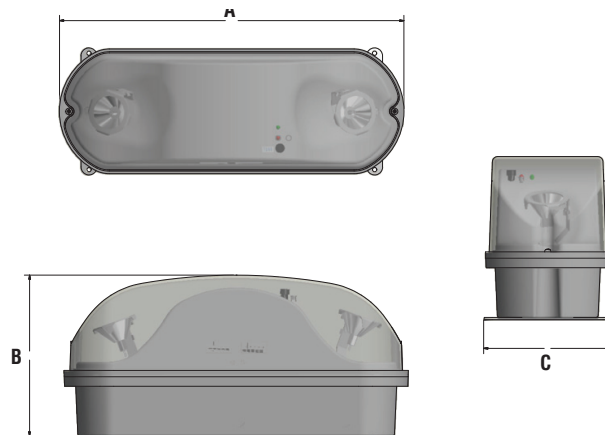

ORDERING INFORMATION

Series & Voltage	Capacity & Battery Type	Lamp Type	Lamp (watts)	Options
EXT-6 (6 volt DC)	18 watts (SLA)	MR16 (halogen)	10W, 12W, or 20W	AT (auto-test)
EXT-12 (12 volt DC)	22 watts (NC)	LED MR16 (LED)	3W, 5W, or 7W (LED)	VM (ammeter)
	27 watts (SLA)			WG (wire guard)
	36 watts (SLA)			CC (cusotm color)
	54 watts (SLA)			IH (internal heater)