

**NIGHTFALL SERIES**  
**CLOUD SHAPED INDOOR LED EMERGENCY LIGHT**

**FEATURES**

- 20 foot on center spacing
- Contoured contemporary low-profile design
- Two (2) 3 watt high powered Cree LEDs, provides 230 total lumens
- Pure white light output of 6500K
- Fully adjustable LED lamps, with no need to remove lenses
- Tool less entry, snap together design
- Universal J-box mounting
- Maintenance-free sealed lead acid battery, standard
- Damp rated, standard
- Standard finish: White, Silver, Black
- External low profile LED status indicator and test button
- 120/277 volt, 60Hz

**WARRANTY**

Any component that fails due to manufacturers defect is guaranteed for 1 year with a separate 1 year pro-rated warranty on the battery. The warranty does not cover physical damage, abuse or acts of God. Manufacturer reserves the right to charge for such repairs if deemed necessary.



The soft corner styling and use of Cree LEDs offers 20 ft on center spacing and makes the NF4 an ideal choice in upgrading your existing traditional emergency lighting to a sleek, high performing, contemporary designed unit. This unit will visually blend into any building design and outperform any traditional incandescent emergency lighting unit.



SPECIFICATIONS ARE SUBJECT TO CHANGE WITHOUT NOTICE

**ORDERING INFORMATION** Example: NF4-WB-SV

Series	Battery	Finish
NF4	WB = With Battery	WH = White
		BL = Black
		SV = Silver

## CONSTRUCTION

The Nightfall Orb series enclosure is constructed of precision molded, high-impact, UL94 V-O flame retardant thermoplastic, resistant to corrosive atmospheres. The NF4 offers completely tool-less entry with unique, fully adjustable, LED lamps for ease of properly aiming light in the needed path of egress.

## ILLUMINATION

Fixtures are supplied with high powered Cree LEDs offering 230 total lumens at 6 watts of light output in a pure white color temperature of 6500K. The LEDs have an estimated life over 50,000 hours with normal use. The high performance Cree LEDs offer 20 ft on center spacing.

## ELECTRICAL

### Input

Dual-voltage input 120 or 277 volt, 60Hz.

### Sealed Lead Acid Battery (Standard)

Extronix sealed lead acid batteries are maintenance-free with a life expectancy of 5 years. Sealed lead acid batteries perform optimally in temperatures ranging from 15-40 degrees C.

### Emergency

The Nightfall Orb series will operate for a minimum of 90 minutes during a loss of power with a 24 hour minimum recharge time for the battery. An extended 120 minute battery is available.

### Brownout Circuit

The brownout circuit monitors the flow of AC current to the unit and triggers the emergency lighting system once a set reduction of AC power occurs. This dip in the voltage will cause many fixtures to extinguish causing loss of normal lighting even though a total power failure has not occurred.

### Low Voltage Disconnect

When the battery's terminal voltage falls below predetermined levels, the low-voltage circuit disconnects the emergency lighting load. The disconnect remains in effect until normal power is restored, preventing deep battery discharge and improving the life of the battery. The disconnect will also automatically reconnect the load circuit once the battery voltage returns to a normal value after charging.

### Solid-State Transfer

The unit features a solid-state switching transistor which eliminates damaged contacts or mechanical failures associated with relays. The switching circuit is designed to detect a loss of AC power and automatically energizes the lamps. Upon restoration of the AC voltage, the emergency lamps will switch off and the charger will automatically recharge the battery.

### Overload and Short-Circuit Protection

The solid-state overload monitoring system in the DC circuit disconnects the lamp load from the battery should excessive wattage demands be made and automatically resets when the overload or short-circuit is removed. This overload current protective characteristic eliminates the need for fuses or circuit breakers for the DC load.

## INSTALLATION

Simple snap together, tool-less entry, offers a universal J-box mounting design stamped into the back plate.

### DAMP LOCATION RATED (Standard)

Damp location rating ensures the fixture is designed to operate safely in outdoor locations that are protected from the direct elements. Damp location rated fixtures may be installed indoors. Products with damp location ratings are not designed to withstand constant or significant moisture or direct contact with water or steam.

## CONFORMANCE TO CODES & STANDARDS

The Nightfall Orb Series is UL listed and meets or exceeds the following: UL 924, NEC requirements and NFPA 101.

## DIMENSIONS

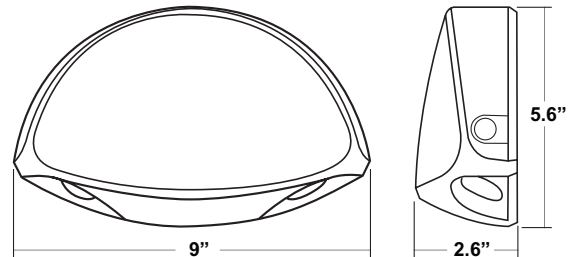

## PERFORMANCE (DOORWAY)

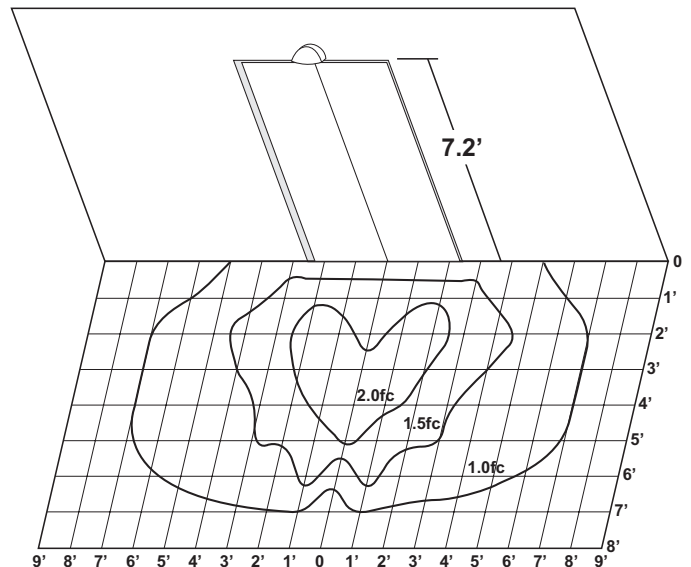

## PERFORMANCE (PATHWAY)

